

# ROOF LADDER CLASS 2 FOR PROFILED SHEET AND FELT ROOFS WITH L FASTENER

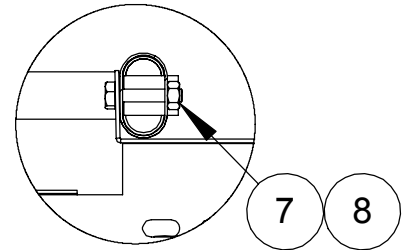

- Snow guards should be used with roof ladders.
- The top end of the modular ladder is fastened through the guide bar by bolting it to the platform beam. Either a bolt fastening or a D ring can be used elsewhere.
- Maximum spacing of the platform beams is 1,400 mm.
- Maximum spacing of the L fasteners is 5,000 mm, the fasteners are fastened with min. 7x30 screws.
- A sealing strip is glued to the bottom of the L fasteners.
- The L fasteners are fastened to the profile ridge with 5 screws per fastener.
- In load-bearing corrugated sheets (W-70/900 and W-115/750), do not install the fastener over the groove!
- In tightening screws, be mindful not to let the screw rotate loosely.
- Please observe the operating and service manuals [www.orima.fi/en/](http://www.orima.fi/en/) and the RT information sheet 85-11132 during installation.
- NOTE! For felt roofs, the recommended thickness of the rough tongue is min. 23x100. The fastener does not need to match the roof truss division.



Fastening the modular ladder to the platform beam

Extending the ladder M8x35 (7)+nut (8)

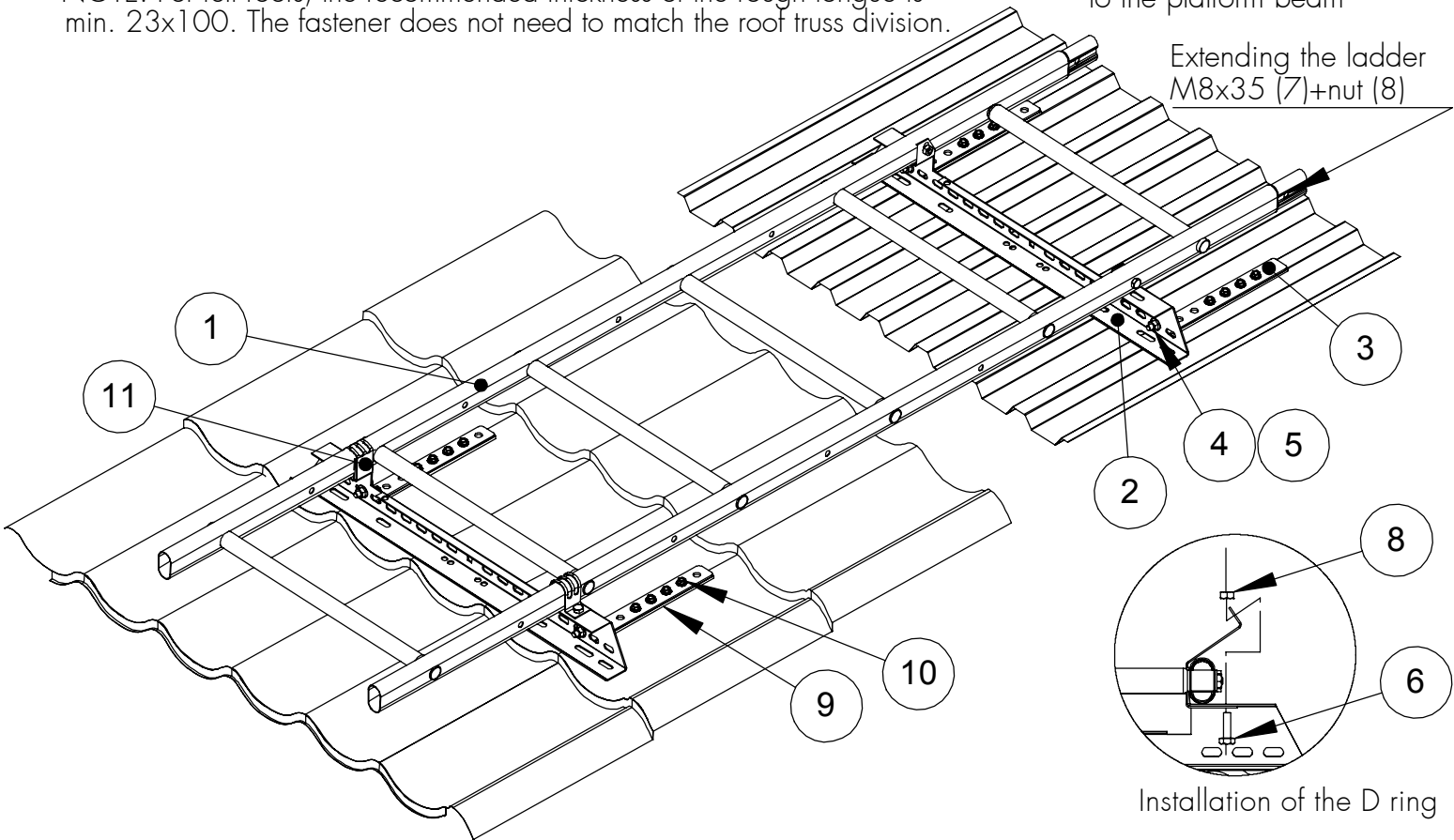

Installation of the D ring

| NO. | PART                | PRODUCT NO. | AS3DC2 (SAS3DC2) | AS3DL (SAS3DL) |
|-----|---------------------|-------------|------------------|----------------|
| 1   | MODULAR LADDER      | *           |                  |                |
| 2   | PLATFORM BEAM       | 20520       | 4                | 1              |
| 3   | L FASTENER          | 22450       | 4                | 2              |
| 4   | FLANGE SCREW M8x20  | 17285       | 4                | 2              |
| 5   | FLANGE NUT M8       | 17201       | 4                | 2              |
| 6   | HEXAGON SCREW M8x16 | 17031       | 6                | 2              |
| 7   | HEXAGON SCREW M8x35 | 17051       | 10               | 4              |
| 8   | HEXAGON NUT M8      | 17021       | 16               | 6              |
| 9   | SEALING TAPE        | 17160       | 1.0 m            | 0.5 m          |
| 10  | SCREW 7x40          | 17941       | 20               | 10             |
| 11  | D RING              | 20530       | 6                | 2              |

\* Ladder frame lengths: 1.2 m, 2.7 m, 3.3 m and 4.2 m.  
 Installation kit AS3DC2 is sufficient for a 4.5-metre ladder.

NOTE! The screw strength M8 8.8(ISO 898) must be used.